

**T**Five    **T**Seven    **T**Nine    **T**Eleven  
2 CHANNEL POWER AMPLIFIER

The Sound of Big Ideas

This page left intentionally blank

## Table of contents

<b>Important safety instructions</b> .....	2
Approvals.....	2
Warning Notice.....	2
Safety rules.....	3
Speaker damage.....	3
Speaker output shock hazard.....	3
<b>Introduction</b> .....	4
More sound and less weight.....	4
Superior Sound-Sonic Accuracy.....	4
Totally Digital with High Reliability.....	4
The Best amplifier for Your Mains.....	4
The T Series.....	4
The Show Always Goes On.....	4
<b>Chapter 1: Installation and operation</b> .....	5
1.1 Unpacking.....	5
1.2 Mounting.....	6
1.3 Operating precautions.....	6
1.4 AC Mains connection.....	6
1.5 Connecting Inputs.....	7
1.6 Connecting Outputs.....	8
1.7 Connecting Remote Control.....	9
1.8 AUX Input CH1/CH2.....	10
1.9 Alarm CH1/CH2.....	10
1.10 AES/EBU Input.....	10
<b>Chapter 2: Setup and settings</b> .....	11
2.1 Introduction.....	11
2.2 The Main screen.....	11
2.3 The main menu.....	12
2.3.1 Output attenuation.....	13
2.3.2 Gain/Sensitivity.....	13
2.3.3 Input select.....	14
2.3.4 Max output voltage.....	14
2.3.5 Max mains current.....	14
2.3.6 Clip limiter CH1-CH2.....	14
2.3.7 Gate CH1-CH2.....	15
2.3.8 Mute at power on.....	15
2.3.9 Idle Mode.....	15
2.3.10 DSP Settings.....	15
2.3.11 Ethernet Settings.....	15
2.3.12 Bar meters.....	15
2.3.13 Output meters.....	15
2.3.14 Temperature.....	16
2.3.15 Mains meters.....	16
2.3.16 Amplifier Name.....	16
2.3.17 Local preset.....	16
2.3.18 Hardware info.....	17
2.3.19 Hardware monitor.....	17
2.3.20 LCD contrast.....	18
2.3.21 Set Keylock code.....	18
2.3.22 Menu locking.....	18
2.3.23 Service.....	18
2.3.24 The Smartcard function.....	19
<b>Chapter 3: Protection</b> .....	20
3.1 Turn-On/Turn-Off muting.....	20
3.2 Short circuit protection.....	20
3.3 Thermal protection.....	20
3.4 DC fault protection.....	20
3.5 Input/Output protection.....	20
<b>Chapter 4: User maintenance</b> .....	21
4.1 Cleaning.....	21
4.2 Dust removal.....	21
4.3 Error codes.....	21
4.4 Service.....	21
<b>Chapter 5: Warranty</b> .....	22
<b>Chapter 6: Assistance</b> .....	22
<b>Chapter 7: Technical notes</b> .....	22
7.1 General Dimension.....	22
7.2 Block diagram.....	23
7.3 Technical specifications.....	24

# Important safety instructions



**CAUTION:** To reduce the risk of electric shock, do not remove the cover. No user-serviceable parts inside. Refer servicing to qualified service personnel.

## KEEP THIS INSTRUCTIONS

**SAFEGUARDS:** Electrical energy can perform many useful functions. This unit has been engineered and manufactured to assure your personal safety. Improper use can result in potential electrical shock or fire hazards. In order not to defeat the safeguards, observe the following instructions for its installation, use and servicing.

## Approvals

The Outline T Series is installed according to the Canadian Electrical Code or National Electrical Code, as applicable.

### T Eleven - T Nine - T Seven

This equipment has been tested and found to compliant by Competent Body (Directive 89/336/EEC-EMC) pursuant to the product family standard for audio professional use:

EN 55103-1 and EN 55103-2 standard ); EN61000- 3 - 2 , EN 61000 - 3 - 3.

Conducted Emissions : Electromagnetic Ambient E1, E2, E3 / Class B

Radiated Emissions : Electromagnetic Ambient E1, E2, E3 / Class B

In a domestic environment this product may cause radio interferences in which case the user may be required to take adequate measures.

This equipment has been tested and found to comply by Notified Body (Directive 2006/95/EEC L.V) pursuant to the audio apparatus safety requirements: Standard EN 60065.

### T Five(\*)

This equipment has been tested and found to compliant by Competent Body (Directive 89/336/EEC-EMC) pursuant to the product family standard for audio professional use:

EN 55103-1 and EN 55103-2 standard ); EN61000- 3 - 2 , EN 61000 - 3 - 3.

Conducted Emissions : Electromagnetic Ambient E1, E2, E3 / Class B

Radiated Emissions : Electromagnetic Ambient E4, E5 / Class A

Radiated Emissions : Electromagnetic Ambient E1, E2, E3 / Class B (\*\*)

In a domestic environment this product may cause radio interferences in which case the user may be required to take adequate measures.

(\*\*) Additional round snap ferrite (of at least 145 Ohm @ 25 Mhz and 265 Ohm @ 100MHz) on Output cables and Mains Cord allows to fulfill Electromagnetic Ambient E1, E2, E3 / Class B on radiate Emissions.

This equipment has been tested and found to comply by Notified Body (Directive 2006/95/EEC L.V) pursuant to the audio apparatus safety requirements: Standard EN 60065.

(\*) T Five pending

## Warning notices

**LOCATION:** Install the amplifier in a well-ventilated location where it will not be exposed to high temperature or humidity.

Do not install the amplifier in a location that is exposed to direct rays of the sun, or near to hot appliances or radiators. Excessive heat can adversely affect the cabinet and internal components. Installation of the amplifier in a damp or dusty environment may result in malfunction or accident.

### Precautions regarding installation

Placing and using the amplifier for long periods on heat-generation sources will affect performances. Avoid placing the amplifier on heat-generating sources. Install this amplifier as far as possible from tuners and TV sets. An amplifier installed in close proximity to such equipment may cause noise or degradation of the picture.

**WARNING:** To prevent fire or electric shock:

- The ventilation should not be impeded by covering the ventilation openings with items such newspapers, table-clothes, curtains etc.
- Do not expose this equipment to rain or moisture.
- Apparatus shall not be exposed to dripping or splashing and no objects filled with liquids, such as vases, shall be placed on the apparatus".

## Safety Rules

This device must be powered exclusively by earth connected mains sockets in electrical networks compliant to the IEC 364 or similar rules.

Is absolutely necessary to verify this fundamental requirement of safety and, in case of doubt, require an accurate check by a qualified personnel.

The constructor cannot be considered responsible for eventual damages caused to persons, things or data for the missing of accurate earth link.

- Before powering this device verify that the amplifier is supplied with the correct voltage rating.
- Verify that your mains connection is capable to satisfy the power ratings of the device.
- Do not spill water or other liquids into or on the unit.
- Do not use this unit if the electrical power cord is frayed or broken.
- Do not remove the cover. Removing the cover will expose you to potentially dangerous voltage.
- No naked flame sources such like lighted candles should be placed on the amplifier.
- Provide sectioning breaker between mains connections and apparatus. Suggested device is 32A/250Vac, C or D curve, 10KA
- The inlet power supply cord plug is useful as disconnection device
- The power cord type is LAPP CABLE OLFLEX191 3G6 / SJT 3XAWG10 SALCAVI (Bahoing SJT 3x16AWG or I-sheng SGIS 3G1,5mmq for T Five)

Contact the authorized center for ordinary and extraordinary maintenance.

## Speaker damage

The Outline T Series amplifiers are among the most powerful professional amplifiers available and are capable of producing much more power than many loudspeakers can handle. It is the user's responsibility to use suitable speakers with the amplifier and to use them in a sensible way that will not cause damage. Outline will not be responsible for damaged speakers. Consult the speaker manufacturer for power-handling recommendations. Even if you reduce the gain using the amplifier's front panel attenuation controls, it is still possible to reach full output power if the input signal level is high enough.

A single high-power crescendo can damage high-frequency drivers almost instantaneously, while low-frequency drivers can usually withstand very high, continuous power levels for a few seconds before they fail. Reduce power immediately if you hear any speaker "bottoming out" - harsh pops or cracking distortion that indicate that the speaker voice coil or diaphragm is striking the magnet assembly. Outline recommends that you use amplifiers of this power range for more headroom (cleaner sound) rather than for increased volume.

## Speaker output shock hazard

A Outline T Series amplifier is capable of producing hazardous output voltages. To avoid electrical shock, do not touch any exposed speaker wiring while the amplifier is operating.

**This manual contains important information on operating your T Series amplifier correctly and safely. Please read it carefully before operating your amplifier. If you have any questions, contact your Outline dealer.**

## Introduction

Outline is a leading company in the field of high efficiency audio power management. The totally new DIGAM (DIGital AMplifier) technology has changed the way the world looks at professional audio amplification. No other amplifiers come close for applications demanding high power and long term reliability. Thanks to amazing reductions in heat output along with reductions in weight and the specific high output power, T Series amplifiers can be used in an unlimited range of applications such as concert touring, opera houses, theatres, churches, cinema, theme parks, television sound stages and industrial applications.

### More sound and less weight

Compared to a conventional amplifier, Outline T Series technology offers very high efficiency and delivers more power to the loudspeakers with much reduced heat dissipation. This greater efficiency enables dimensions, weight and power consumption to be reduced. The output stages of the amplifiers typically run at 95% efficiency, dissipating only 5% of the input energy as heat.

One of the most interesting characteristics is that efficiency is almost independent of output level. Conventional amplifiers achieve their best efficiency only at full rated power output. Since standard music has an average power density of 40% of the maximum level, conventional amplifiers can easily generate 10 times more heat than T Series for the same volume of sound.

### Superior Sound-Sonic Accuracy

Crystal-clear highs, and a tight, well-defined low end: the most accurate reproduction of an audio signal. Patented design features ensure very high performance in parameters such as distortion, frequency response, slew rate, power bandwidth and dumping factor.

### Totally Digital with High Reliability

The T Series is based on PWM technology that has been used for 30 years or more in power supplies and inverters. PWM provides high reliability, small size, low weight and high efficiency. A PWM converter works as a high frequency sampler, converting the variable amplitude (audio) signal into an impulse sequence with average value equal to the audio input.

T Series amplifiers use very high sampling frequencies to obtain high performances across the audio band.

### The Best Amplifier for Your Mains

Outline adopt Power Factor Correction. This feature ensures that a predominantly resistive load is presented to mains, minimizing current distortion and voltage/current displacement. This leads to much improved performance of the amplifier at high levels of output and avoids mains-voltage collapses, typical of standard and switching power supplies. Another great advantage of this technology is that its performance is, to a large extent, independent of mains voltage. The rated output power does not vary with load/line conditions.

### The T Series

T Series has many advanced features, Digital control of many parameters, adjustable maximum mains consumption, selectable digital presets and a graphic display that shows detailed information of the status of the amplifier. You can appreciate the functionality of these and a lot of other features by reading this manual carefully.

### The Show Always Goes On

T Series is completely protected against every possible error in operation and is designed to work under every condition. It gives you maximum power with maximum safety and increases long-term reliability. Anticipating potential problems at the design stage means your show always goes on!

# 1 Installation and operation

## 1.1 Unpacking

Carefully open the shipping carton and check for any noticeable damage; the figure below shows the exploded view of the packing. Every Outline amplifier is completely tested and inspected before leaving the factory and should arrive in perfect condition. If you find any damage, notify the shipping company immediately. Be sure to save the carton and all packing materials for the carrier's inspection.

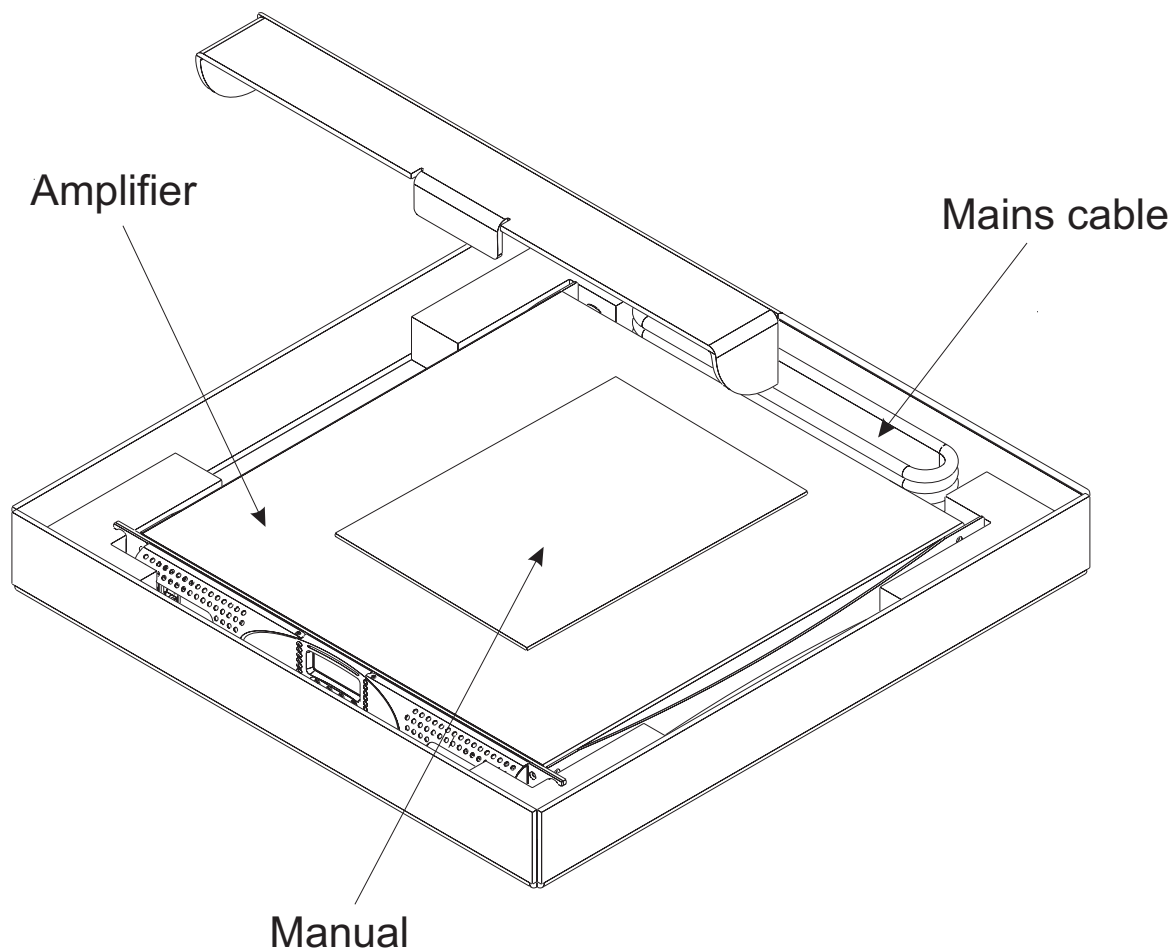

figure 1.1

### 1.2 Mounting

All T Series amplifiers are previewed for the standard 19" rack mounting; there are four front panels holes and four rear lateral holes. The amplifiers must be fixed into rack in both sides, back and frontal, to avoid mechanical damages. Your amplifier uses a forced-air cooling system to maintain a low, even operating temperature. Drawn by an internal fan, air enters through the slots in the front panel and courses over and through components. The T Series amplifiers feature an "intelligent" variable-speed DC fan which is controlled by heat sink temperature sensing circuits: the fan speed will increase only when the temperature of either heat sink requires it, which keeps fan noise to a minimum and helps cut dust accumulation inside. Under extreme thermal load, the fan will force a very large volume of air through the heat sinks. If either heat sink gets too hot, its sensing circuit will reduce the output power. If the amplifier overheats, another sensing circuit shuts down its circuit to cut off power until it cools to a safe temperature.

The exhaust cooling air is forced out through the rear of the chassis (see figure 1.2.1), so make sure there is enough space around the sides of the amplifier to allow the air to escape. If it is rack mounted, make sure the exhaust air can flow without resistance. If you are using a rack with closed backs, there must be at least one standard rack space of opening in the front of the rack for every four amplifiers. Amplifiers may be stacked directly on top of each other (no space needed between units), starting from the bottom of the rack.

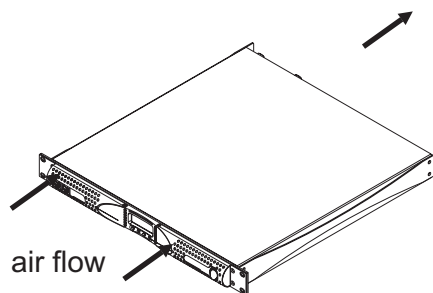

figure 1.2.1

### 1.3 Operating Precautions

Make sure the AC mains voltage is correct and is the same as that printed on the rear of the amplifier. Damage caused by connecting the amplifier to improper AC voltage is not covered by the warranty. Make sure the power switch is off before making any input or output connections.

It is always a good idea to have the gain controls muted during power-up to prevent speaker damage if there is a high signal level at the inputs.

Whether you buy them or make them, use good-quality input and speaker cables. Most intermittent problems are caused by faulty cables. Use good-quality connectors and wire, along with good soldering technique, to ensure troublefree reliability.

### 1.4 AC Mains connection

The AC Main connection is made via the CPC type connector (IEC20A for T Five) on the rear side of the panel. The figure below shows the connection to the amplifier. Be sure that your AC mains power source has the requirements indicated in this manual. The T Series amplifier has an automatic power factor correction system for a perfect mains network interface. The amplifier is a resistive load for the mains network, minimizing the reactive power and the harmonic distortion on the current. The system allows performance to be maintained even in circumstances of varying the mains voltage. **Is important to connect the ground for safety, do not use adapters that disable the ground.**

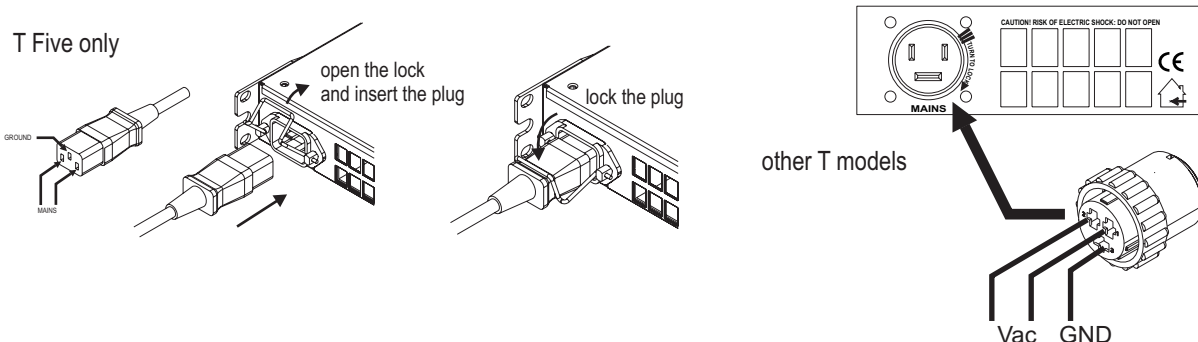

figure 1.4.1



**1.5 Connecting Inputs.** Input connections are made via the 3-pin XLR-female type or 1/4" phone Jack connectors on the rear side of the amplifier. The polarity is shown in figure 1.5.1.

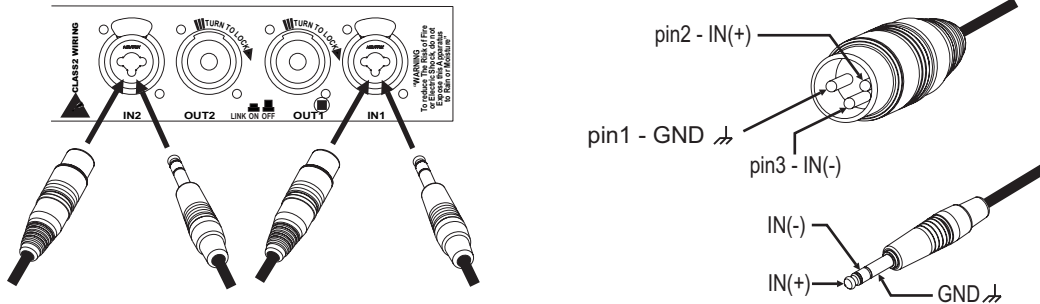

figure 1.5.1

The figure below shows the connection of analog input for balanced and unbalanced line. You can use both configuration, but you must consider that unbalanced long line can introduce noise in the audio system. The Link switch located in the rear panel is for direct paralleling the rear input connectors. You can use the remaining input connector to carry signal to other amps.

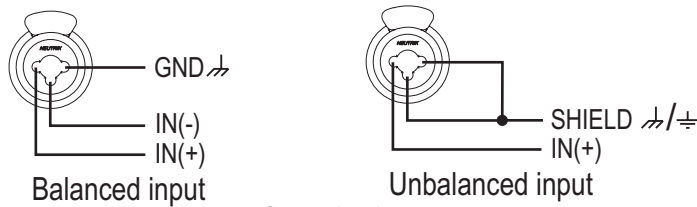
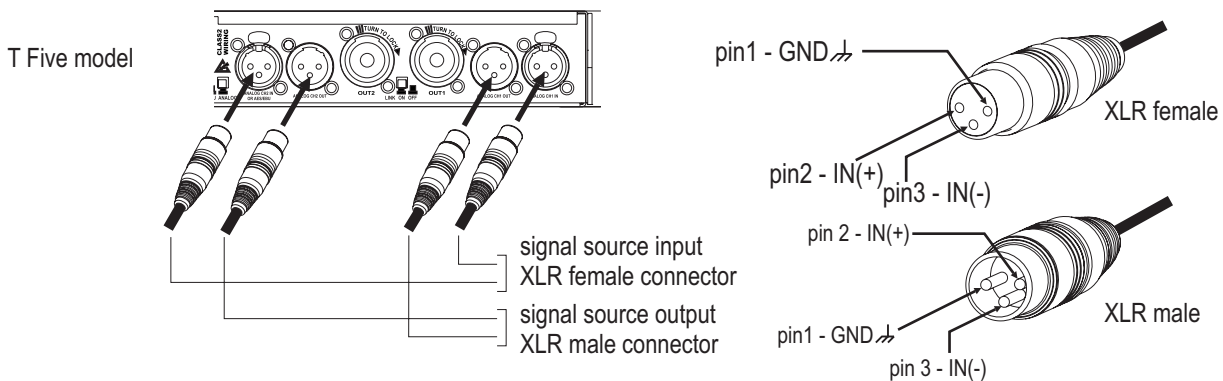

figure 1.5.2

For T Five, the input connections are showed in the figure below; analog input for balanced and unbalanced line is also available for this models.



### 1.6 Connecting Outputs

**Warning: there are lethal voltages at the loudspeaker connectors when the amplifier is turned on. To prevent any damages turn the amplifier off before connecting the loudspeaker**

Output connectors are made via neutrik speakon connectors. Consult the wire gauge chart to find a suitable wire gauge to minimize power and damping factor losses in the speaker cables. The outputs can also work on bridge mode. For each device the 1+ and 2+ pins of speakon connector are connected inside and have to be considered the positive output of the channel; the 1- and 2- pins of speakon connector are connected inside and have to be considered the negative output of the channel.

Note: Channel B is always polarity reversed output stage, but polarity compensated by feeding the minus pins of the channel B output with the output voltage. Channel A is connected in the polarity mode. By having channel A and B operating in opposite polarity, the energy storage in the power supply is more efficient. This is significant for signals below 100Hz (sub bass etc.) and improves the power bandwidth. **Be sure to use balanced inputs on all measurement equipment (also oscilloscope probes) in you are bench testing.**

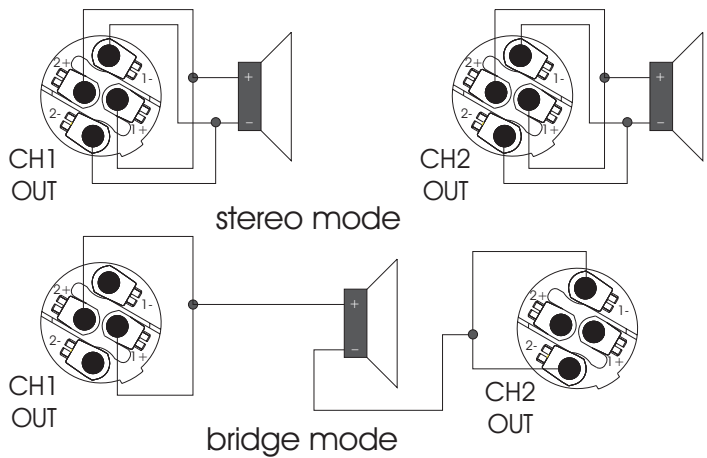
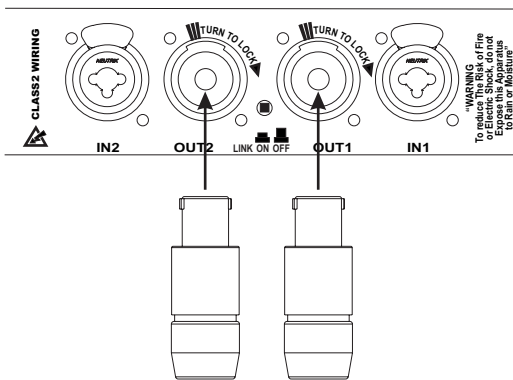
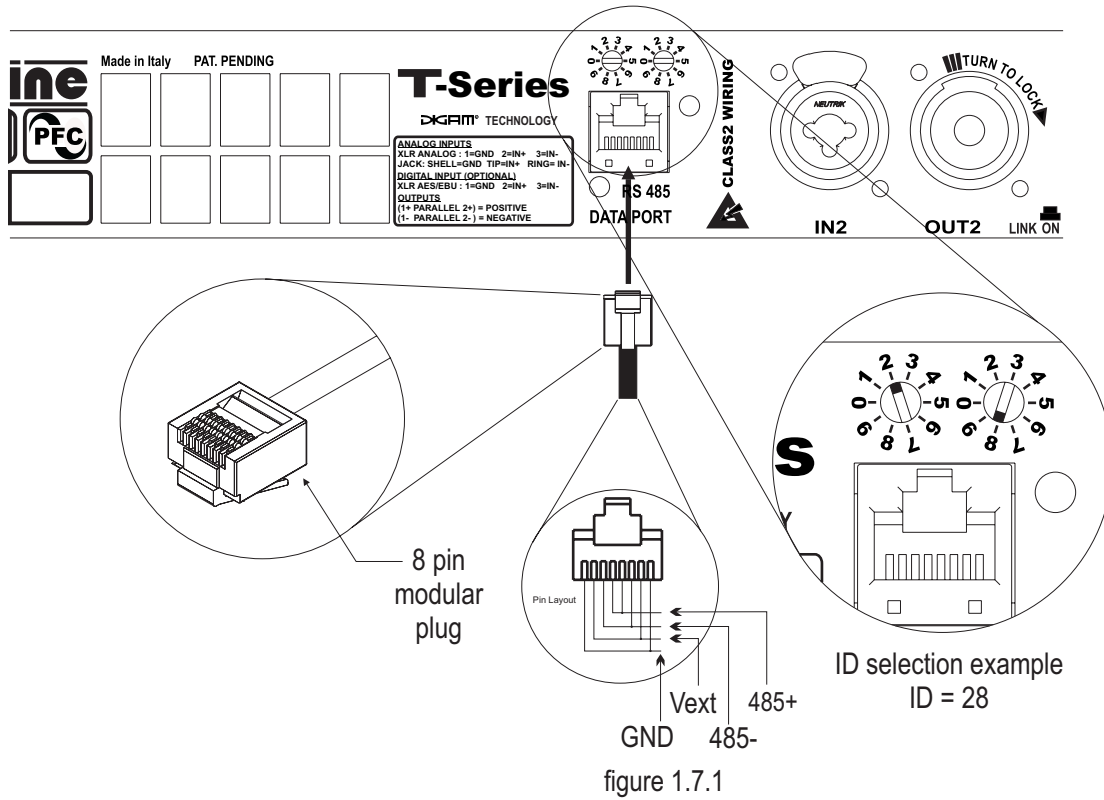

figure 1.6.1

### 1.7 Connecting Remote Control

You can control the amplifier via a RS485; The figure 1.7.1 shows the connection of the data cable to the plug located to the rear panel of the amplifier. connection. The same figure shows also the ID selection for Remote Control (in this case ID= 28); to change the ID, rotate the selectors at the desired value. The selected ID value also is shown in Hardware info section ( see par 2.3.18 ).



### **1.8 AUX Input CH1/CH2**

These inputs are automatically selected in place of the line input CH1/CH2 when an external voltage of 24V DC is applied through the AUX COMMAND input, these inputs can be used for emergency signals as pre-recorded evacuation messages or similar alarm messages.

### **1.9 Alarm CH1/CH2**

Relays output 24V outputs to command external equipment; alarm relays output normally closed, open for reporting amplifier faults

### **1.10 AES/EBU Input**

On DSP equipped amplifiers CH2 is the AES/EBU input.

## 2 Setup and settings

### 2.1 Introduction

The figure below shows the front panel of Outline T Series. The front panel controls, in conjunction with the graphic LCD display above the buttons, give to the user the total control and detailed information about the status of the amplifier. Each pushbutton has multiple functions and the display shows the current active function for each button. Read carefully the instructions below that help you to manage the functions of the amplifier.

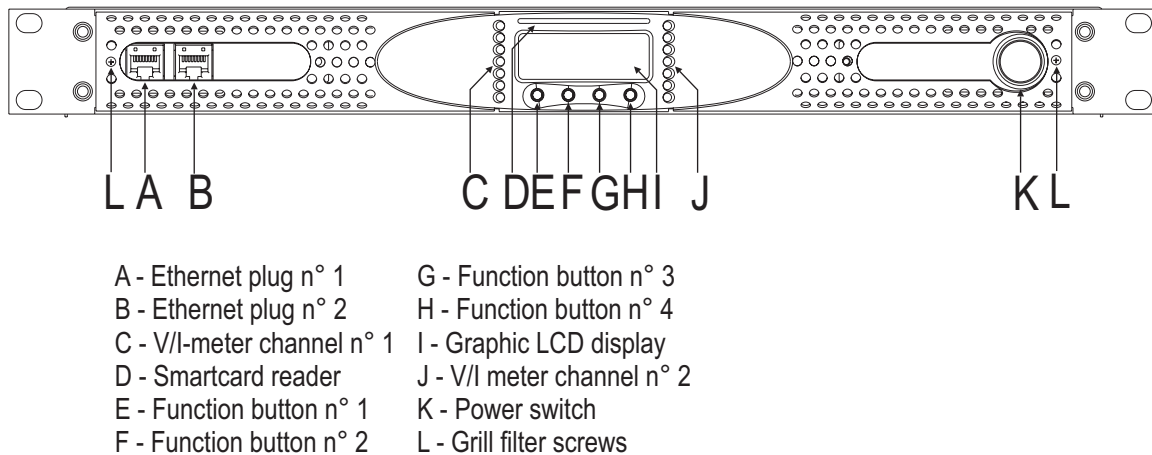

figure 2.1.1

### 2.2 The main screen

The figure 2.2.1 show the main screen; this screen appears after a short presentation when the user powers on the amplifier. In the first line, after power on, the writing "WAIT" appears; if the system parameters are normal, the writing are replaced with "READY". During the normal operation the controller monitors the system parameters. If a parameter is out of range, the correspondent code error is written on the LCD meter of the relative channel in the third line; if the abnormal parameter is associated to both channel, the error code is written in the center.

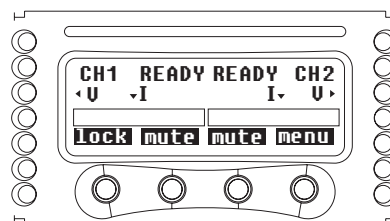

figure 2.2.1

The LED bars can function as output voltage or output current meters; in the first case the LCD meters function as output current meter, viceversa in the second case. The first green LED at the bottom side of the LED bar indicates, when lighted, the presence of input audio signal above -60 dBV on the corresponding channel; the 2nd, 3rd and 4th LED in the ascending order indicates an output level of -3dB, -6dB and -10dB respectively. The green LEDs will be lighted during normal working. The yellow LED will light at -1 dB. If the level of the audio signal reach the channel output capability, red LED will be triggered.

The LED bars have diagnostic function also; a flashing yellow LED indicates a critic range of temperature (from 80°C to 85°C) of the power devices on the corresponding channel, if this LED is lighting constantly, the temperature is above 85°C. A lighting constantly red LED indicates that the corresponding channel is under protection and in this case the writing "PROT" appears in the first line of the display.

The fourth line of the screen shows the functions of the buttons below.

The "lock" function is activated if the corresponding button is pressed more than 1 second; in this case all the other buttons are locked. The same operation unlocks these buttons (unlock code is required - see par. 2.3.17 for more details).

The "mute" buttons switch off the two channels independently; in this case the parameters of the correspondent channel disappear and the writing "muted" appears on the third line. The same operation disables the mute function.

If the "menu" button is pressed, the main menu is displayed on the LCD screen.

### 2.3 The main menu

The figure 2.3.1 shows the main menu. You can scroll the menu items by pushing the up or down buttons and choose the selected one by pushing "ok" (if the chosen item enables or disables a function, the writing "on" is replaced with "off" for disabling it, or "on" for enabling it. The menu tree is shown in figure 2.3.2.

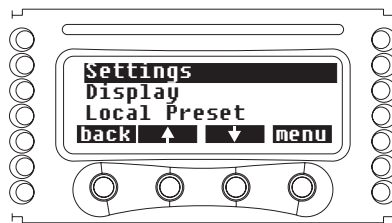

figure 2.3.1

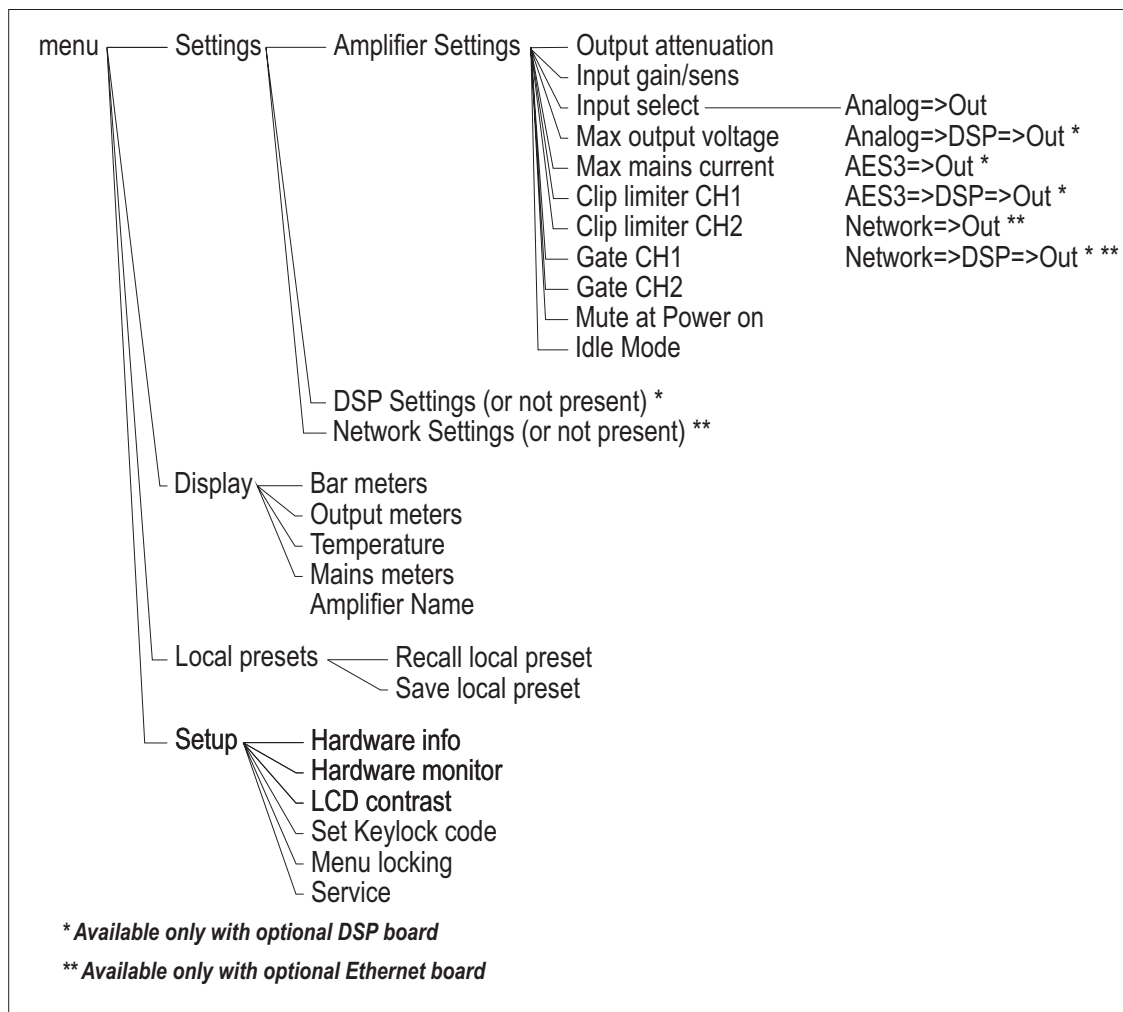

figure 2.3.2

To better handle the huge amount of parameters, the single value numeric input mode is extended with a fine/coarse feature. When you edit one of the parameters, you will start in the "fine" mode. The steps applied by the - and + keys are the minimum allowable for that parameter. By clicking the "fast" key shown in figure 2.3.3, you will switch in the "coarse" mode, and the key will be renamed as "slow" as shown in figure 2.3.4. In the coarse mode, the steps are equivalent to 10 steps of the fine mode, so that editing will be 10 times faster. Remember that by keeping the - or + key pressed, the steps are automatically repeated.

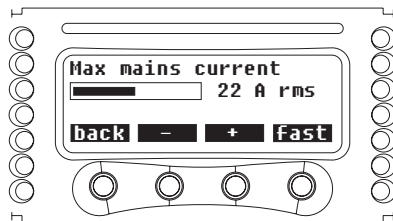

figure 2.3.3

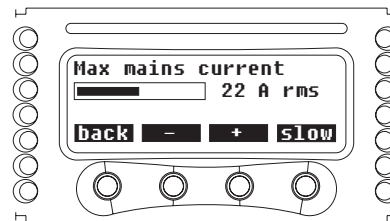

figure 2.3.4

### 2.3.1 Output attenuation

The figure 2.3.5 shows the Output attenuation screen. You can choose to set CH1, CH2 or both by pushing the "C1+2" button. The "+" and "-" buttons change the value of the output attenuation in the range from 0 to -30dB.

**Note: for the best sonic performance it is preferred to set the 0db output attenuation (no attenuation), and select the proper gain/sensitivity by the following menu.**

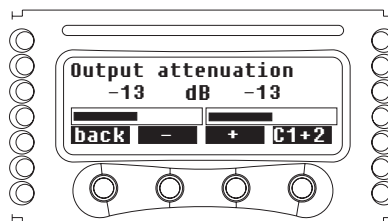

figure 2.3.5

### 2.3.2 Gain/Sensitivity

The figure 2.3.6 shows the Gain/Sensitivity screen. You can choose to set CH1, CH2 or both by pushing "C1+2" button. The "+" and "-" buttons change the value of the gain. The values of gains permitted are 26, 29, 32 and 35 dB; the corresponding values of sensitivity and maximum input voltage are written in the table below.

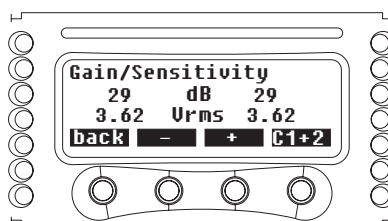

figure 2.3.6

GAIN	MODEL			
	T Five	T Seven	T Nine	T Eleven
26	5,29	5,10	5,50	6,32
29	3,76	3,62	3,90	4,45
32	2,66	2,55	2,75	3,16
35	1,88	1,81	1,96	2,23

values of sensitivity (Vrms)

GAIN	ACCEPTANCE		
	dBV	dBu	Vrms
26	25,0	27	18
29	21,6	24	12
32	19,0	21	9
35	15,6	18	6

values of maximum balanced input

### 2.3.3 Input select

You can choose among three different input modes (if available): Analog, Digital AS3\* with or without DSP processing and Ethernet\*\*. The up and down buttons change the selection; the "sel" button locks the selected option.

\* Available only with optional DSP board

\*\* Available only with optional Ethernet board

### 2.3.4 Max output voltage

The figure 2.3.7 shows the Max output voltage screen. You can choose to set CH1, CH2 or both by pushing "C1+2" button. The "+" and "-" buttons change the value of the max output peak voltage. The ranges available are showed in the table below

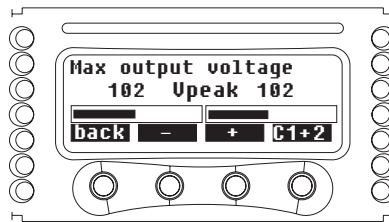

figure 2.3.7

#### MODEL

T Five	T Seven	T Nine	T Eleven
from 40 to 165	from 40 to 153	from 40 to 169	from 40 to 200

Values of peak voltage (V)

### 2.3.5 Max mains current

The figure 2.3.8 shows the Max mains current screen. The "+" and "-" buttons change the value of the max mains current input in the range from 15 to 32A (8 to 16A for T Five). Maximum mains current limit set the rms value at which a C-Type current breaker will trip-off.

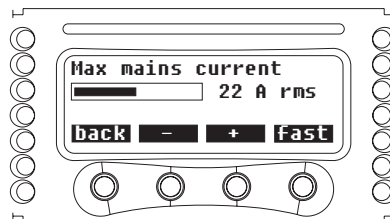

figure 2.3.8

### 2.3.6 Clip limiter CH1 - CH2

Enable this function to prevent the distortion due to excessive amplitude of output signal. You can enable/disable it by pushing the on/off button.

**CAUTION: There is the risk of damage to the loudspeakers, if Clip Limiters are deactivated. You should not deactivate Clip Limiters unless their function is taken over by external devices, such as digital system controllers. In such cases it is mandatory, to properly adjust parameters in the external device.**



### 2.3.7 Gate CH1 - CH2

This function allows to mute the amplifier channels individually if input signal amplitude is falling below the values shown in the following table. You can enable/disable it by pushing the on/off button. Gating the output is delayed by 5 seconds after input signal removal, and follows in reversed way the bottom green LED on the CH1, CH2 bar LED display \*(muted if green LED is off).

		TRESHOLD VALUES OF INPUT SIGNAL DETECTOR		
		dBV	dBu	mVrms
GAIN (dB)	26	-54	-52	2
	29	-57	-55	1,41
	32	-60	-58	1
	35	-63	-61	0,707

### 2.3.8 Mute at power on

If enabled, the amplifier will be always in mute state for both channels at power on; you can mute off the channels independently in the main screen, but in this mode the amplifier will be in the mute state at the next power on.

### 2.3.9 Idle Mode

The idle mode function is a power saving feature. By activating it, if the amplifier doesn't detect the signal for the user defined amount of time, the output stage is turned off, saving about 40 W of power per channel. This means reduced heating, longer amplifier and fans life, and, especially for fixed installation permanently turned on, a lower electricity bill.

### 2.3.10 DSP Settings

This sections is implemented if optional DSP board is present.

### 2.3.11 Ethernet Settings

This sections is implemented if optional Ethernet board is present.

### 2.3.12 Bar meters

In the Bar meters screen you can choose if the LED bars operate as output voltage meter and LCD bar in the main screen as output current meter (by selecting "LED Volt, LCD Curr), or viceversa (by selecting the other item).

### 2.3.13 Output meters

In the Output meters screen you can view the values of the output signal for CH1 and CH2. Furthermore, the impedance of the load is showed in the bottom line of the screen (see figure 2.3.9). Minimum of output voltage for impedance measurements is 10Vrms, measurements values are stored into logbook. Time between single impedance measurements can be up to several minutes depending on program signal. Output power is shown as maximum value every 200 mS.

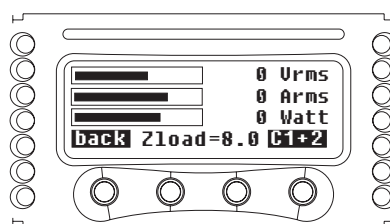

figure 2.3.9

In "C1+2" mode the screen shows the output values in bridge connection.

### 2.3.14 Temperature

In the Temperature screen you can view the historic temperature diagram of the last four hours of the final current use in the range from 10 to 90°C; in the bottom-right side of the screen there is the present value (see figure 2.3.10).

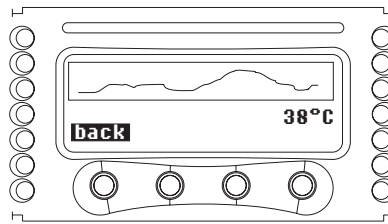

figure 2.3.10

### 2.3.15 Mains meters

In the Mains meters screen you can view the voltage and the current of the mains (see figure 2.3.11).

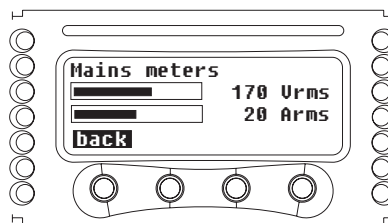

figure 2.3.11

### 2.3.16 Amplifier Name

The amplifier name, together with the current preset name, can be displayed by enabling the “Display amplifier data” function. The 20 characters amplifier name, together with the 40 characters preset name is shown in a different way when the amplifier is in the starting page of the main menu. The amplifier name can be assigned by the “Edit amplifier name” command (for the text editing, see Local preset handling section).

### 2.3.17 Local preset

There is the possibility to store up to 50 presets on amplifier local memory.

By choosing the Save local preset command, the current amplifier configuration (basic amplifier settings + TDSP board settings if DSP board is present) is stored on the local memory. To proceed, the menu asks to choose one of the 50 available presets (see figure 2.3.12), showing the preset number and name. If the preset was never used, it is named <empty>. By pressing ok, you can enter the preset name. The selected character is pointed by the arrow shown in Figure 2.3.13, and by pressing or + keys it is modified. By pressing sel key, next character is selected as shown in figure 2.3.14. When the name input is finished, by pressing the ok key, the preset is stored

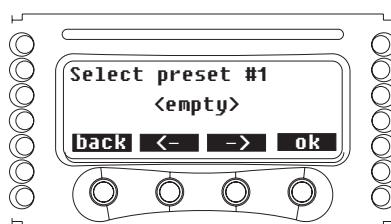

figure 2.3.12

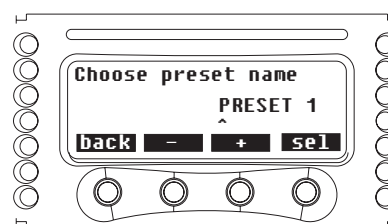

figure 2.3.13

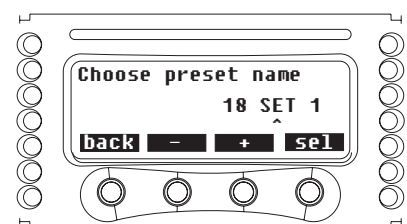

figure 2.3.14

The Recall local preset command loads and applies one of the stored presets, chosen through an identical dialog. Please note that all the current amplifier settings are overwritten!

Note that if you have already input a preset name, or if you have loaded a preset from local memory or smartcard, the name is kept by the amplifier and used as starting point for a new save preset operation.

For example, suppose that you have loaded a preset named "18IN SUB 1" from a SC, and then you save it into local memory as shown in figure 2.3.15. In this case the menu shown in figure 2.3.16 asks you if you want to keep/edit that name (shown figure 2.3.17) or if you would like to edit the name of the preset that is going to be overwritten (shown figure 2.3.18). This is useful for copying presets from/to smartcard.

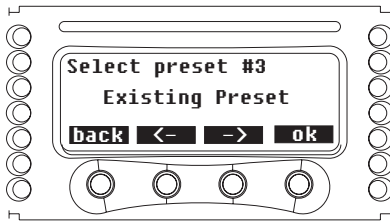

figure 2.3.15

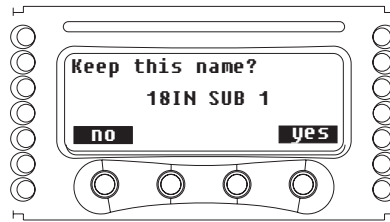

figure 2.3.16

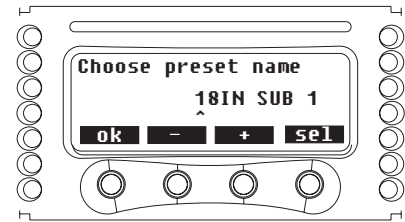

figure 2.3.17

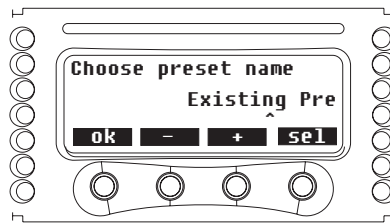

figure 2.3.18

### 2.3.18 Hardware info

In this screen you can view some information about the hardware of the amplifier:

- **S/N** the serial number of the amplifier
- **HW ID** the hardware identifier (selectable by rear panel rotary encoders)

if you push the "more" button, you can view the other info

- **KFRNT** the version number of the front panel
- **KCTRL** the version number of the controller
- **KDSP** the version number of the DSP board
- **KETH** the version number ethernet adapter

if you push the "more" button, you can view the other info

- **Lifetime** the operating time of the amplifier

### 2.3.19 Hardware monitor

In this screen you can view some information about the system parameters:

- **PWRBSCH1 - PWRBSCH2** amplifier power supply voltages channel 1-2
- **VAUX** internal auxiliary voltages

if you push the "more" button, you can view the others parameters:

- **+5VAN** auxiliary analog voltage
- **VEXT** external remote control voltage
- **VAUX** if the "OK" written is displayed, auxiliary voltages of power supply are correct.
- **IGBTCONV** if the "OK" written is displayed, the DC/DC converter monitor function properly
- **192KHZ** if the "OK" written is displayed, the frequency system clock is right
- Power Supply primary KBUS (Vboost)
- Clock frequency

### 2.3.20 LCD contrast

In this screen you can set the contrast of the LCD display by pushing the +/- buttons (see figure 2.3.19).

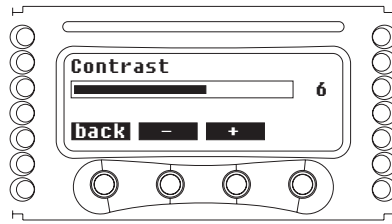

figure 2.3.19

### 2.3.21 Set keylock code

In this screen you can insert the numeric key to unlock the settings; the same screen appears when the "unlock" button in the main screen is pressed. There is a universal key to unlock the settings: this is **270156**.

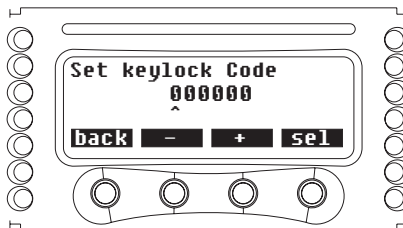

figure 2.3.20

### 2.3.22 Menu locking

In addition to the basic pushbutton locking function, a new menu locking strategy was introduced. There are three levels of locking: All locked, Allow safe, Allow all.

**All locked:** only the menus for displaying infos are enabled, the other are hidden. Presets cannot be loaded.

**Allow safe:** user can change from Analog input to AES3 input, always with DSP into the signal path. Some common DSP parameters can be changed (AES3 gain trim, main delay, DSP input selection)\*. Only local presets can be recalled, and they should be all safe for the speaker system connected to that amplifier (example: HF driver 3 dB, HF driver 0 dB, HF driver +3 dB).

**Allow all:** all settings menus are enabled. User can recall presets from either local memory or smartcard.

Furthermore, local presets can be made Read-Only by enabling the "Lock presets" function, in order to preserve the original settings stored on the amplifier.

The lock code, when set different from 000000, protects the whole Menu locking submenu.

\* Available only with optional DSP board

### 2.3.23 Service

The key to activate this function is factory reserved.

### 2.3.24 The Smartcard function

There is the possibility to store up to 150 presets for each settings smartcard (shown figure 2.3.21). The menu is activated when the smartcard is inserted in the amplifier, **only if** the main page of the menu is selected. The store and recall procedures are identical to those used for local presets as shown in figure 2.3.22.

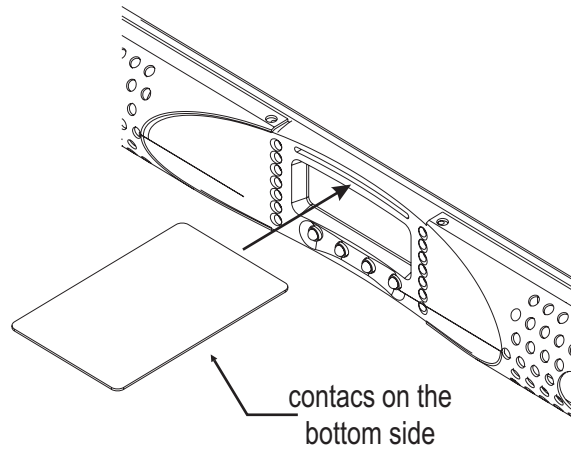

figure 2.3.21



figure 2.3.22

You can select the desired option by pushing up or down button and "ok" to activate it. The option "Recall local preset" does not appear if the smartcard is blank.

## 3 Protection

### 3.1 Turn-On/Turn-Off muting

For about four seconds after turn-on, and immediately at turn-off, the amplifier outputs are muted.

### 3.2 Short circuit protection

A short circuit protection system safeguards the amplifier's output transistors under short circuits and other stressful loads. It is completely inaudible when inactive. In case of short circuit, the red LED will be light-up and writing "PROT" appears in the first line of the display(see Par. 2.2 for a detailed description). The amplifier will reset himself 5 times every 2 seconds. Once 50 resets have been performed and the fault still exists on the output, the unit sets into steady protection mode. Turn ON/OFF cycle is needed to restart the unit.

### 3.3 Thermal protection

A T series amplifier uses a continuously variable speed fan to assist cooling (the fan speed changes in response to the amplifier's cooling needs). If the heat sink temperature reaches approximately 80°C, the yellow LED starts to flashing. If the temperature is more than 85°C the thermal sensing circuitry will mute each power section channels, the LED will light permanently and the power supply will be cut off. Once the heatsink has cooled down, the amplifier will automatically reset and the LED will be go out. It is possible to reduce the temperature by reducing the output power.

### 3.4 DC fault protection

If DC or excessive subsonic energy appears at a channel output, an instantaneous protection circuit will cut off the power supply for both channels. Power supply shutdown is used instead of speaker relays, thereby improving the damping factor and reliability of the amplifiers.

### 3.5 Input/Output protection

An ultrasonic network decouples RF from the outputs and keeps the amplifier stable with reactive loads.

## 4 User maintenance

### 4.1 Cleaning

Disconnect the amplifier from the AC main source first; use a soft cloth and mild non-abrasive solution to clean the faceplate and chassis.

### 4.2 Dust removal

Especially in a dusty environment, the front side filters clog with dust after prolonged use, this will interfere with cooling. You may use compressed air to remove the dust from filters. To remove air filters see fig(3.4.1) , unscrew n° 2 M2,5X8 screw and rotate the covering grill; repeat the same operation on the other side.

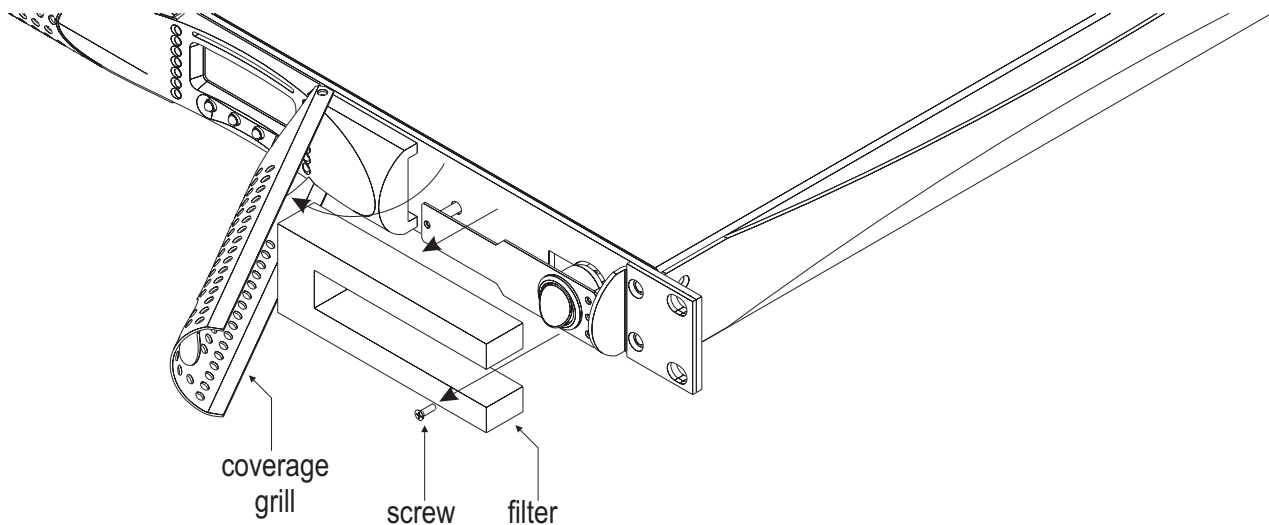

figure 4.3.1

### 4.3 Error Codes

Error code	Error descr.
1	192KHz clock not present
2	Positive 15V aux
4	Negative 15V aux
8	Positive 5V analog
100	Negative power bus Ch1
200	Negative power bus Ch2
2000	Positive power bus Ch1
4000	Positive power bus Ch2
8000	External auxiliary voltage
Check rail fuses	Check rail fuses Ch1 and Ch2

The error code value displayed in the main screen is the sum of the single error code value.

**Example:** 4301=4000+200+100+1 **means**

Positive power bus Ch2 +  
 Negative power bus Ch2 +  
 Negative power bus Ch1 +  
 192KHz clock not present

### 4.4 Service

There are no user-serviceable parts in your amplifier. Refer servicing to qualified technical personnel.

In addition to having an in-house service department, Outline supports a network of authorized service centers. If your amplifier needs repair, contact your Outline dealer or distributor, or contact the Outline Technical Service department, to obtain the location of the nearest authorized service center.

## 5 Warranty

Outline prides itself on the quality and reliability of its products that are designed and manufactured to meet the highest quality standards. We are also proud of the great care we assure to our customers. We are confident that you will never have a need to take advantage of this warranty, but in the unlikely event of a failure or deviation in performance, we'll do our very best to get you swiftly back in business.

Outline amplifiers warranty is calculated from the original date of purchase from an Authorized Outline Dealer. During this time, if your amplifier fails for any defect in components and/or labour under a correct and regular use, it will be repaired or, at our sole opinion, replaced without any charge a part for the transport expenses to return the unit at Outline premises. The repaired/replaced amplifier will be finally returned to you with the original shipping carton at our charge.

The Warranty conditions will not be applied in case the amplifier has been ulteriorly damaged by repair attempts, inadequate or poor packaging, any kind of improper use/maintenance (overvoltage, incorrect connection, use with wrong or faulty associated equipment or accessories, exposure to rigid weather conditions, excess moisture, etc...).

Warranty terms will not be consider for any unit where the serial number has been removed and or it is not clearly readable. Outline is not responsible for any incidental or consequential damages; the responsibility is limited to the product itself. Outline reserves the right to make changes or improvements in design or manufacturing without assuming any obligation to change or improve product previously manufactured.

## 6 Assistance

The local Outline distributor/reseller will be glad to support you in case of fault or for any additional information. If you cannot contact your local distributor/reseller, please mail to [info@Outline.it](mailto:info@Outline.it)

**Do not ship any unit to Outline for Factory Service before having had the Outline authorization.**

## 7 Technical notes

### 7.1 General Dimension

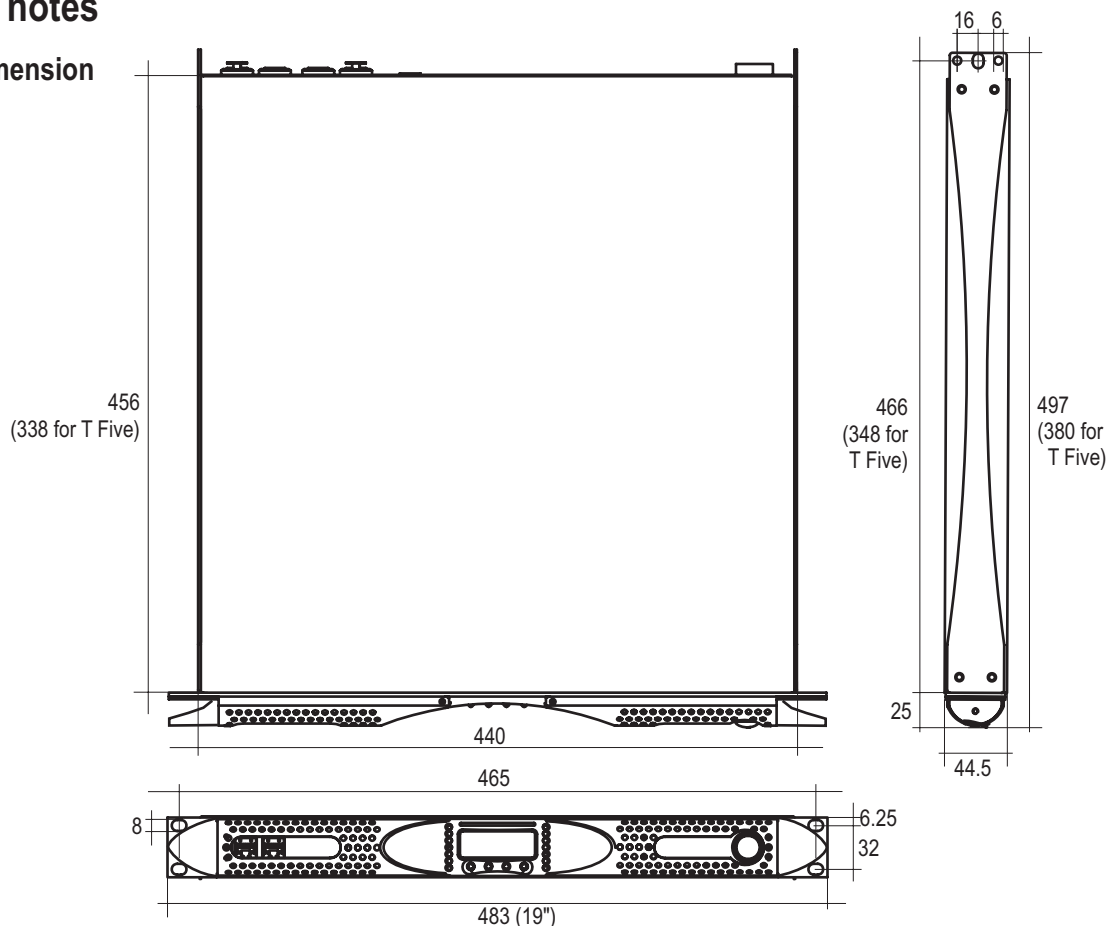



### 7.2 Block diagram

The figure 7.1.1 shows the the output stage block diagram, the figure 7.1.2 shows the power supply block diagram.

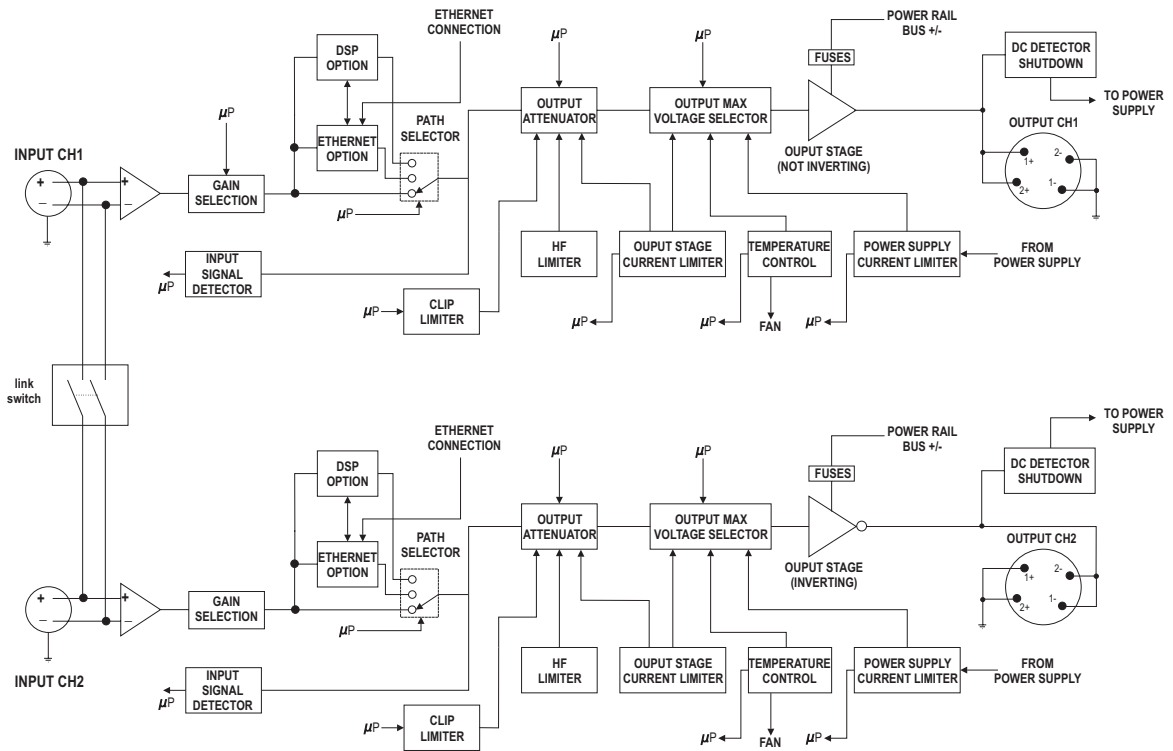

figure 7.1.1

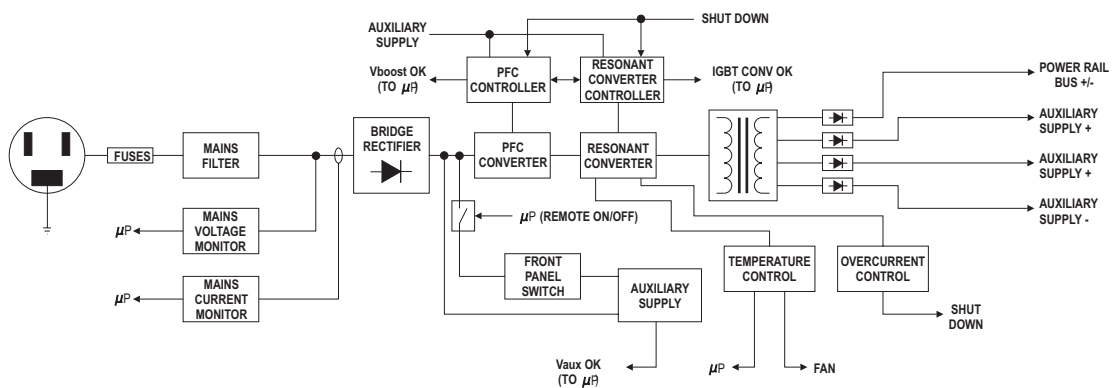

figure 7.1.2

## 7.3 Technical specifications

### POWER REQUIREMENTS

Power supply.....115÷230V(-15%, +15%)  
 Power factor.....more than 0,95 (0,90 for T Five) from 500W to full power  
 Operating temperature ..... 0° C, 45° C  
 Weight.....8Kg (17,6 lbs) for T Five, 12Kg (26,5 lbs)  
 External dimensions.....Standard rack 19" (W), 1 Units (H), 497mm (D), 380mm (D) for T Five

### AUDIO SECTIONS

Bandwith (1W, 8Ohm).....20Hz, 20KHz ±0,2 dB  
 Damping factor (8Ohm)..... (20Hz, 200Hz) > 5000  
 Slew Rate (8Ohm).....50V/uS (input filter bypassed)  
 S/N ratio..... >112 (T Five), >108 (T Seven), >109 (T Nine), >110 (T Eleven)  
 Distortion THD..... Max < 0.5% from 1W to full power (typically < 0.05%)  
 Intermodulation SMPTE ..... Max < 0.5% from 1W to full power (typically < 0.05%)  
 Intermodulation DIM 30..... Max<0.5% from 1W to full power (typically < 0.05%)  
 Inputs.....Balanced to ground, XLR female combo jack 6.3mm; XLR with parallel on XLR (T Five)  
 Impedance.....10KOhm each leg balanced to ground  
 Gain .....26, 29, 32, 35dB, user selectable  
 Outputs... .....High current Neutrik 4-pole Speakon connectors (pins 1+ 2+ paralleled, 1-2- paralleled)

### OUTPUT SPECIFICATIONS

Power WATT (EIAJ)  
 (1KHz, 1% THD)

Stereo mode

Bridged mono

	<i>T Five</i> <i>T Seven</i> <i>T Nine</i> <i>T Eleven</i>				<i>T Five</i> <i>T Seven</i> <i>T Nine</i> <i>T Eleven</i>				
2 Ohm	2800	3600	4800	6000	4 Ohm	n.a.	7200	9600	12000
4 Ohm	2600	2500	3000	4000	8 Ohm	n.a.	5000	6000	8000
8 Ohm	1400	1300	1500	2000	16 Ohm	n.a.	2600	3000	4000

Max voltage output: *T Five* *T Seven* *T Nine* *T Eleven*  
 165V 153V 169V 200V

Max current output: *T Five* *T Seven* *T Nine* *T Eleven*  
 75A 85A 85A 85A

### FEATURES

- Worldwide mains operating voltage
- Power Factor Correction (PFC)
- LED bar indicator
- Over-temperature Forecasting
- Thermal protection
- Short - Circuit protection
- Over-Load
- Output protection
- Temperature controlled air cooling system
- Clip limiter and permanent signal limiter
- LCD matrix interactive display
- Digital gain - attenuation control
- Smart Card management
- User selectable maximum output power
- User selectable maximum mains current draw
- Remote control - diagnostic

Option DSP/Ethernet

This page left intentionally blank

---

## NOTES

---

---

---

---

---

---

---

---

---

---

---

---

---

---

---

---

---

---

Outline carries out on-going research for product improvement. New materials, manufacturing methods and design upgrades are introduced to existing products without prior notice as a routine result of this philosophy. For this reason, any current Outline product may differ in some aspect from its description, but will always equal or exceed the original design specifications unless otherwise stated.

© Outline 2008  
Operating manual product code: Z OMTSERIES  
Release: 081201  
Printed in Italy